

QUADRAPHONIC AMPLIFIER

QA-800 / FVW

NOTE: Concerning the following, refer to:

1. Service manual of model QM-800 on page 15: packing method and parts,
2. Service manual of model QC-800 on pages 11 and 29: circuit description and parts list of Q unit (AWM-001), and
3. Service manual of model QC-800 on page 32: parts list of lever switch unit (AWS-002).

CONTENTS

1.	SPECIFICATIONS	3
2.	FRONT PANEL FACILITIES	5
3.	CONNECTION DIAGRAM	7
4.	CIRCUIT DESCRIPTION	9
5.	DISASSEMBLY	12
6.	ALIGNMENT PROCEDURES	14
7.	SCHMATIC DIAGRAMS AND PCB PATTERNS	
7-1	UNIT CONNECTION DIAGRAM	15
7-2	HEAD AMP UNIT (W15-032)	16
7-3	CONTROL AMP UNIT (AWG-001)	17
7-4	Q UNIT (AWM-001).....	18
7-5	MAIN AMP UNIT (AWH-002)	20
7-6	POWER SUPPLY UNIT (AWR-002)	22
7-7	LEVER SWITCH UNIT (AWS-002)	23
7-8	LEVER SWITCH UNIT (AWS-003)	24
7-9	VOLUME UNIT (AWX-001)	25
7-10	R UNIT (AWX-005)	26
8.	PARTS LIST	
8-1	MISCELLANEOUS PARTS	27
8-2	HEAD AMP UNIT (W15-032)	28
8-3	CONTROL AMP UNIT (AWG-001)	29
8-4	MAIN AMP UNIT (AWH-002)	30
8-5	POWER SUPPLY UNIT (AWR-002)	32
8-6	LEVER SWITCH UNIT (AWS-003)	33
8-7	VOLUME UNIT (AWX-001)	33
8-8	R UNIT (AWX-005)	33

1. SPECIFICATIONS

SEMICONDUCTORS

Transistors	51
Diodes	9

POWER AMPLIFIER SECTION

Music Power Output (IHF)	204W (4 Ω) 144W (8 Ω)
Continuous Power Output (2 channels driven)	34W + 34W/34W + 34W (4 Ω) 27W + 27W/27W + 27W (8 Ω)
Continuous Power Output (4 channels driven)	24W x 4 (4 Ω) 20W x 4 (8 Ω)
Power Output in the range of 20Hz to 20kHz (2 channels driven)	23W + 23W/23W + 23W (8 Ω , Harmonic Distortion Less than 0.5%)
Harmonic Distortion	Less than 0.5% (Continuous power output)
Intermodulation Distortion	Less than 0.8% (Continuous power output)
Power Bandwidth (IHF)	15Hz to 50kHz (8 Ω), 4 channels driven, Harmonic Distortion Less than 0.5%) 10Hz to 50kHz (8 Ω , 2 channels driven, Harmonic Distortion Less than 0.5%)
Frequency Response	8Hz to 70kHz, \pm 1dB
Input Sensitivity/Impedance (1kHz, Continuous power output)	500mV/50k Ω
Speakers	4 to 16 Ω
Phones Jacks	For [CH.1, CH.3] & [CH.2, CH.4]
Damping Factor	40 (8 Ω , 1kHz)

PREAMPLIFIER SECTION

Output Voltage	500mV (Rated output)
Harmonic Distortion	Less than 0.08%
Frequency Response	20Hz to 40kHz, \pm 1dB
Input Sensitivity/Impedance (1kHz, for rated output)	PHONO 1, 2 2.5mV/50k Ω (2 CH.) TUNER 200mV/100k Ω (4 CH.) AUX 1, 2 200mV/100k Ω (4 CH.) TAPE MONITOR 1, 2 200mV/100k Ω (4 CH.)
Recording Output	TAPE REC 1, 2 (Pin jack) 200mV (4 CH.)
BASS Control	-10dB, + 10dB/100Hz
TREBLE Control	-10dB, + 10dB/10kHz
LOW Filter	-10dB/50Hz
HIGH Filter	-10dB/10kHz
Equalization Curve	PHONO : RIAA S.T.D.
Loudness Contour	+11dB/100Hz, +7dB/10kHz with volume control set at -40dB position
Muting	-20dB
Hum and Noise (IHF)	PHONO More than 80dB TUNER, AUX More than 90dB
Channel Separation (1kHz)	PHONO More than 40dB TUNER, AUX More than 50dB

MISCELLANEOUS

Power Requirements	110V, 120V, 130V, 220V and 240V. (Switchable)	
	50 – 60Hz	
Power Consumption	400W (Max.)	
Dimensions (overall)	16- $\frac{15}{16}$ in./430mm (width)	
	5- $\frac{11}{16}$ in./145mm (height)	
	13- $\frac{1}{4}$ in./337mm (depth)	
Weight	Without package	24lb, /10.9kg
	With package	28lb,6oz/12.9kg
Furnished Accessories	Pin Plug	8
	Speaker Plug	6
	Fuse (1.5A)	1
	Fuse (3A)	2
	Polishing Cloth	1
	Operating Instructions	1
	Connection cord (L, R)	2

NOTE: Specifications and the design subject to possible modification without notice due to improvements.

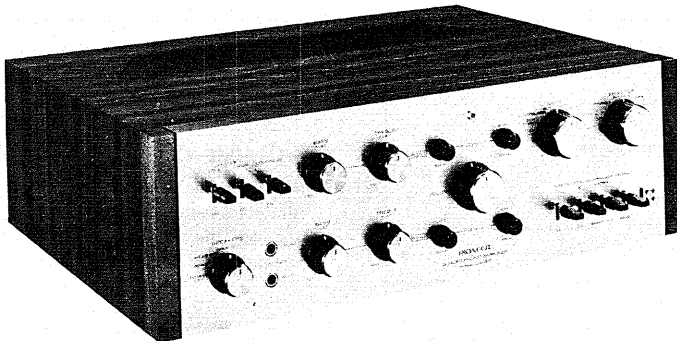

2. FRONT PANEL FACILITIES

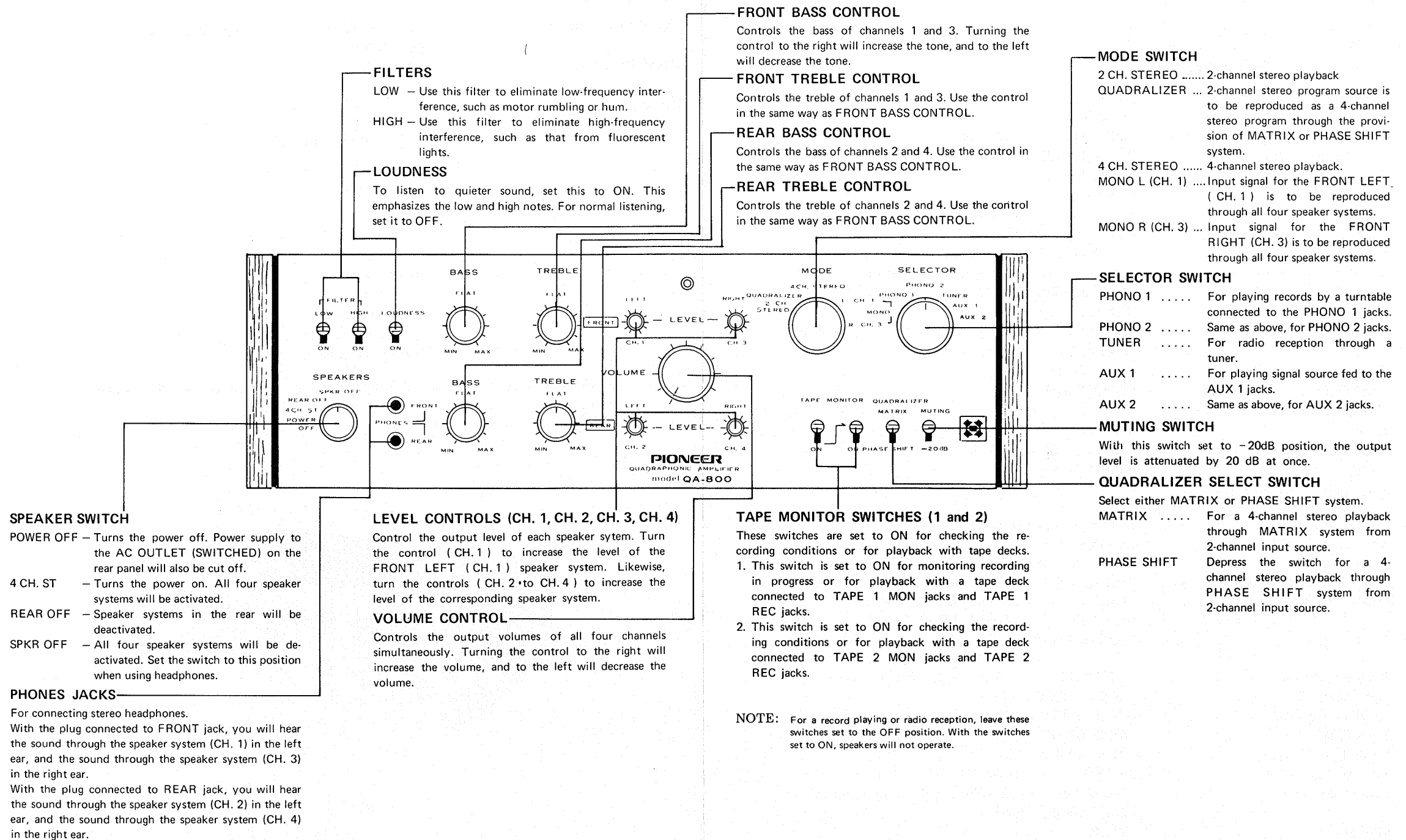

3. CONNECTION DIAGRAM

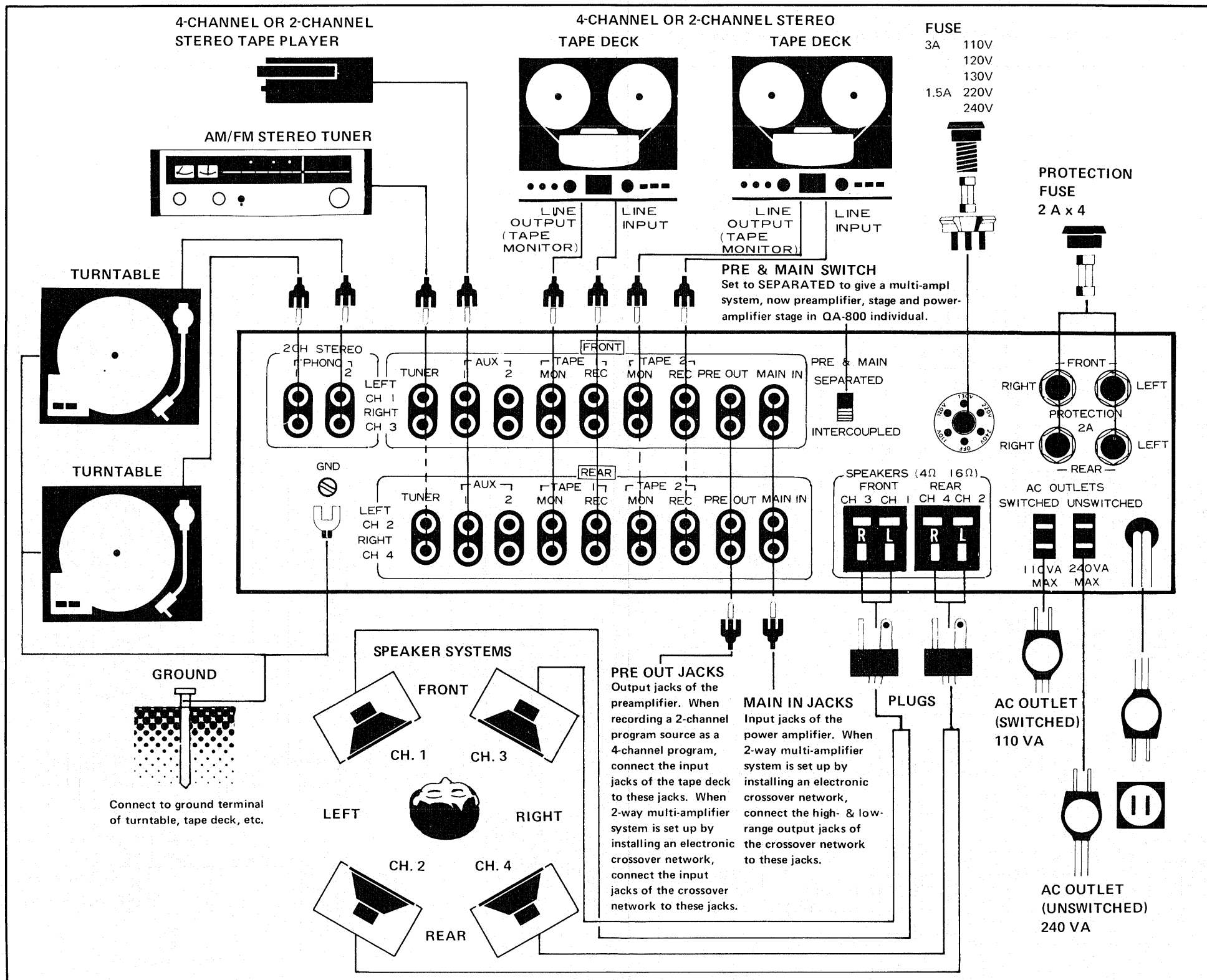

4. CIRCUIT DESCRIPTION

4-1 BLOCK DIAGRAM

The block diagram shows the signal path in the QA-800 as well as the auxiliary circuits such as the power supply.

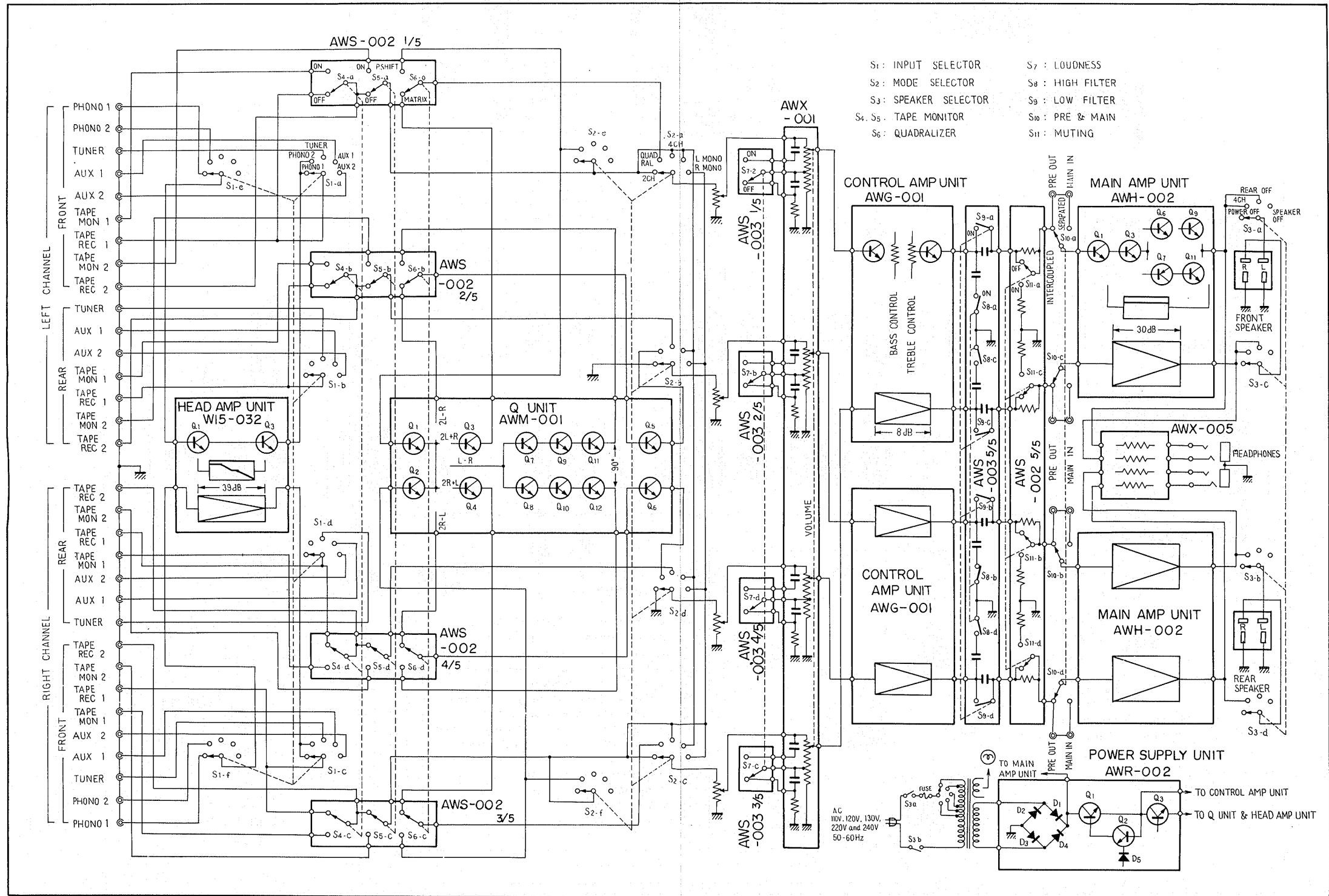

4-2 LOW LEVEL INPUT CIRCUITS

Low level signals such as from a phono cartridge are supplied into the PHONO 1 and 2 input jacks.

Program sources are selected by the input selector S1.

4-3 HEAD AMPLIFIER

The complete head amplifier is contained on PCB No. W15-032, consisting of two directly coupled circuits. The overall negative feedback loop circuit for equalization is connected from the collector of Q3 to the emitter of Q1.

The equalization characteristic is RIAA playback for PHONO.

4-4 HIGH LEVEL INPUTS AND CONTROL CIRCUITS

High level inputs such as AUX 1, 2 and TUNER are also selected by S1. Input from tape deck and recording output signal (a head amplifier output or a direct output from a high level input) are switched by TAPE MONITOR switches (S4 and S5), respectively. The selected signal then passes to mode switch S2, balance and volume controls.

5-5 CONTROL AMPLIFIER

This stage, consisting of two transistors and tone controls, is embodied on PCB No. AWG-001.

The top amplifier stage obtains stable, high impedance under all conditions.

Bass and treble control circuits are connected between collector and base of Q3.

4-6 FILTER

The filter stage is embodied on PCB No. AWS-003.

Filter design uses an RC network of 6dB/oct.

4-7 POWER AMPLIFIER CIRCUIT

The power amplifier circuit assembled in the PCB No. AWH-002 consists of six transistors (Q1, Q3, Q5, Q7, Q9 and Q11) for each channel. Overall NFB is applied from output to the emitter of Q1, thus improving distortion and frequency response. Transistors Q3, Q5, Q7, Q9 and Q11 are all direct coupled, stabilizing the circuit by applying NFB in both AC and DC. The thermistor stabilizes temperature characteristics.

4-8 POWER SUPPLY

Q1 and Q2 are a voltage regulator, supplying low-ripple rectified current to the control amplifier section.

The other voltage for the head amplifier and Q unit section is obtained from the voltage regulator through ripple filter Q3. For the power amplifier voltage is obtained from a bridge rectifier. All parts except the filter capacitor and power transformer are located on PCB No. AWR-002.

5. DISASSEMBLY

5-1 WOODEN CASE

Remove the 4 screws from the sides of the wooden case. Pull the case backward off the amplifier housing.

5-2 FRONT PANEL

Pull off all knobs, then remove nuts and washers from shafts as shown in Photo 2. The front panel can now be removed.

5-3 BOTTOM PLATE

The bottom plate can be removed after loosening the 8 screws.

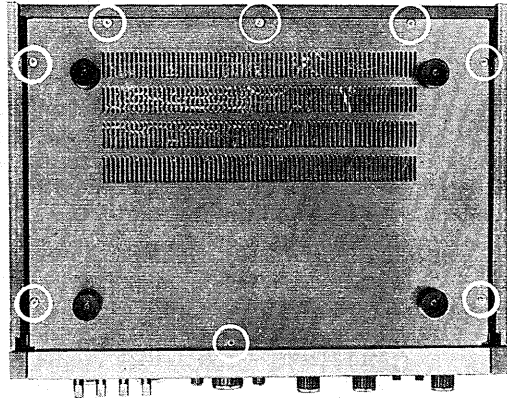

Photo 3

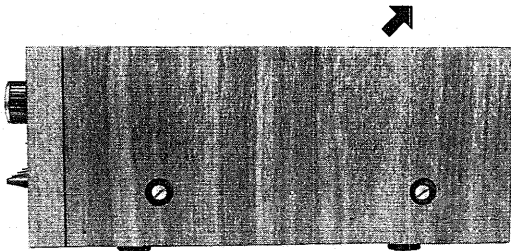

Photo 1

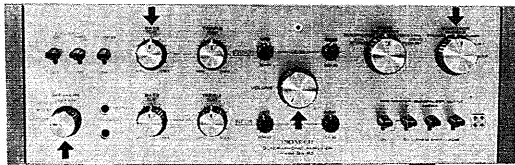
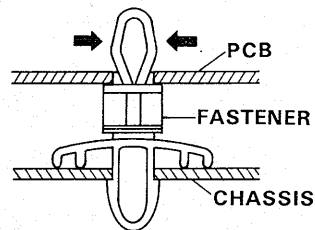

Photo 2

NOTE: When removing unit, please observe:

1. Don't simply pull unit up to remove, as this may damage hole or fastener boss. Damaged fastener cannot be repaired.
2. Squeeze upper part of fastener with small tweezers as indicated by arrows in illustration, then pull unit upward.
3. Fasteners once removed from chassis cannot be used again as they lose strength.



5-4 PARTS AND PCB LOCATION

TOP VIEW

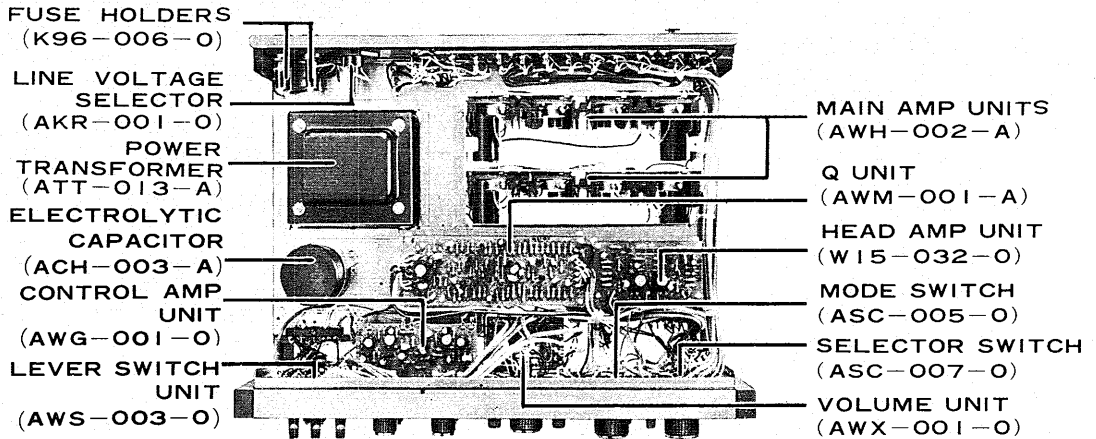

BOTTOM VIEW

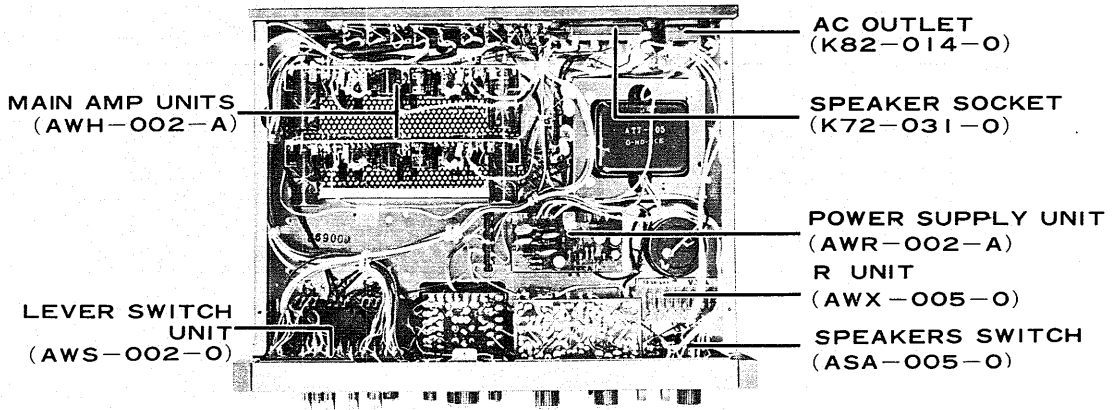

6. ALIGNMENT PROCEDURES

6-1 DC NEUTRAL VOLTAGE ALIGNMENT

- a) Set all controls as follows:
 INPUT SELECTOR AUX 1
 MODE SELECTOR ... 4 CH. STEREO
 TAPE MONITOR SWITCHES OFF
 BASS, TREBLE CONTROLS ... FLAT
 LOUDNESS SWITCH OFF
 LOW, HIGH FILTER SWITCHES OFF
 MUTING SWITCH OFF
 PRE & MAIN SWITCH SEPARATED
 LEVEL AND VOLUME CONTROLS MIN
 SPEAKER SWITCH POWER OFF
- b) Set SPEAKERS switch to 4 CH. STEREO position.
- c) Connect voltmeter between Q11 collector and E3 on PCB AWH-002.
- d) Adjust VR1 on PCB AWH-002 for 28V meter reading.
- e) Connect voltmeter between Q12 collector and E4 on PCB AWH-002.
- f) Adjust VR2 as in step (c).

6-2 IDLE CURRENT ADJUSTMENT

- a) Set all controls as in 6-1 (a). Then:
 - Connect AC cord to AC outlet.
 - Set SPEAKERS switch to 4 CH. STEREO position.
 - Allow a few minutes for amplifier to warm up.
- b) Set voltmeter near 0.1V full scale range, connect between TP1 and E3 on PCB AWH-002.
- c) Adjust VR3 on PCB AWH-002 to obtain meter reading of 0.01V ± 20%.
- d) Connect voltmeter between TP2 and E4 on PCB AWH-002.
- e) Adjust VR4 as in step (c).

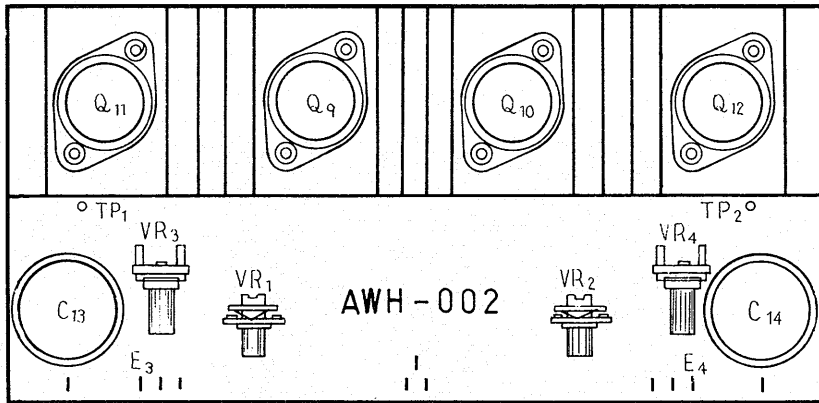

7. SCHEMATIC DIAGRAMS AND PCB PATTERNS
7-1 UNIT CONNECTION DIAGRAM

QA-800

QA - 800

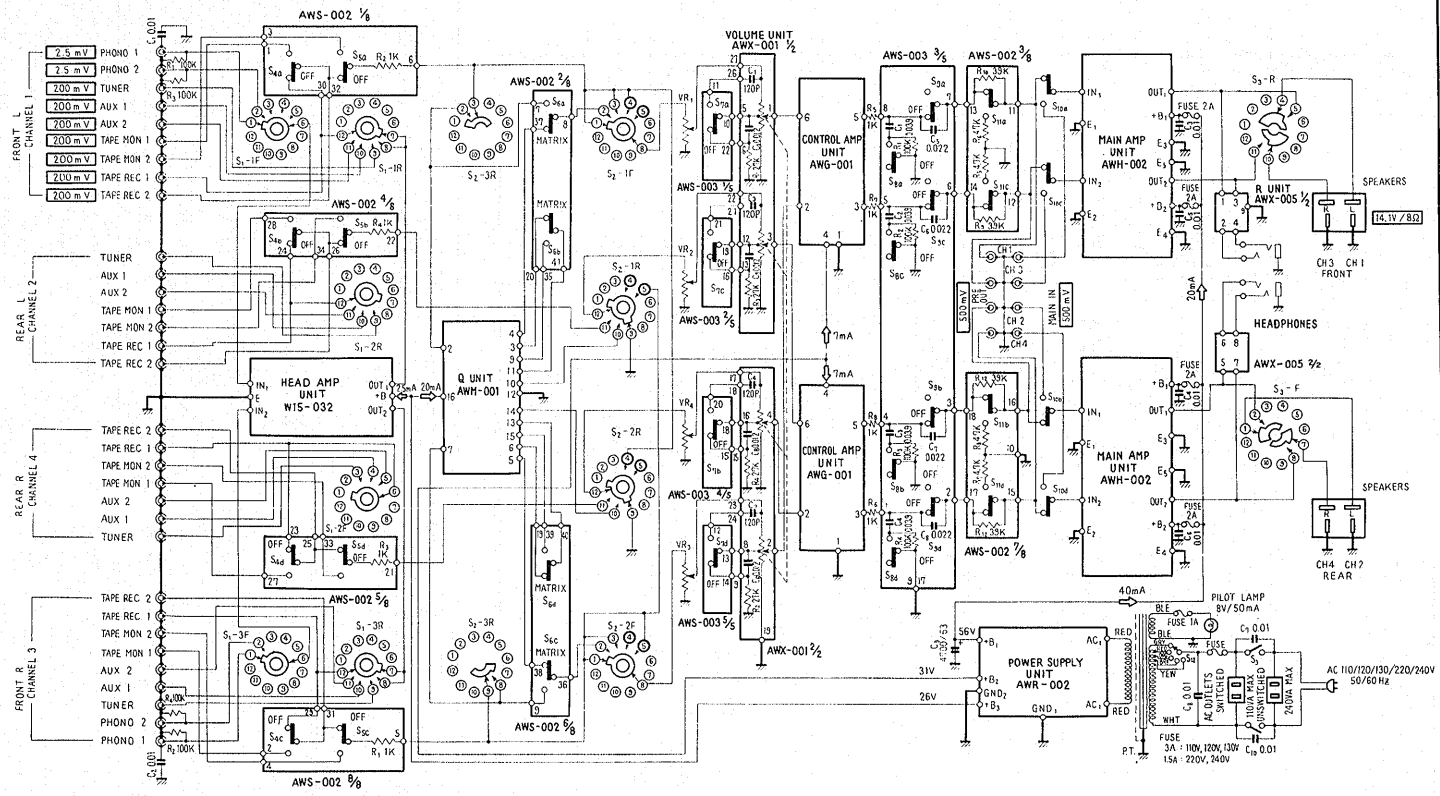

SWITCHES
S₁: SELECTOR
(1) PHONO 1
(2) PHONO 2
(3) TUNER
(4) AUX 1
(5) AUX 2

S₂: MODE
(1) 2 CH STEREO
(2) QUADRALIZER
(3) 4 CH STEREO
(4) L CH-1) MONO
(5) R CH-3) MONO

S₃: SPEAKERS
(1) POWER OFF
(2) REAR OFF
(3) REAR OFF
(4) SPEAKER OFF

S₄: TAPE MONITOR 1 OFF -- ON
S₅: TAPE MONITOR 2 OFF -- ON
S₆: QUADRALIZER MATRIX -- PHASE SHIFT
S₇: LOUDNESS OFF -- ON
S₈: HIGH FILTER OFF -- ON
S₉: LOW FILTER OFF -- ON
S₁₀: PRE & MAIN INTER COUPLED -- SEPARATED
S₁₁: MUTING OFF -- ON

POTENTIOMETERS
VR₁: LEVEL CONTROL (CH 1)
VR₂: LEVEL CONTROL (CH 2)
VR₃: LEVEL CONTROL (CH 3)
VR₄: LEVEL CONTROL (CH 4)
VR₅: VOLUME CONTROL

RESISTORS
NON MARK: OHM
K: KILOHM
M: MEGOHM
CAPACITORS
NON MARK: μF
μ: μμF

⊖: SIGNAL VOLTAGE AT 25W/8Ω OUTPUT
∇: DC VOLTAGE AT NO INPUT SIGNAL
→: DC CURRENT AT NO INPUT SIGNAL

7-2 HEAD AMP UNIT (W15-032)

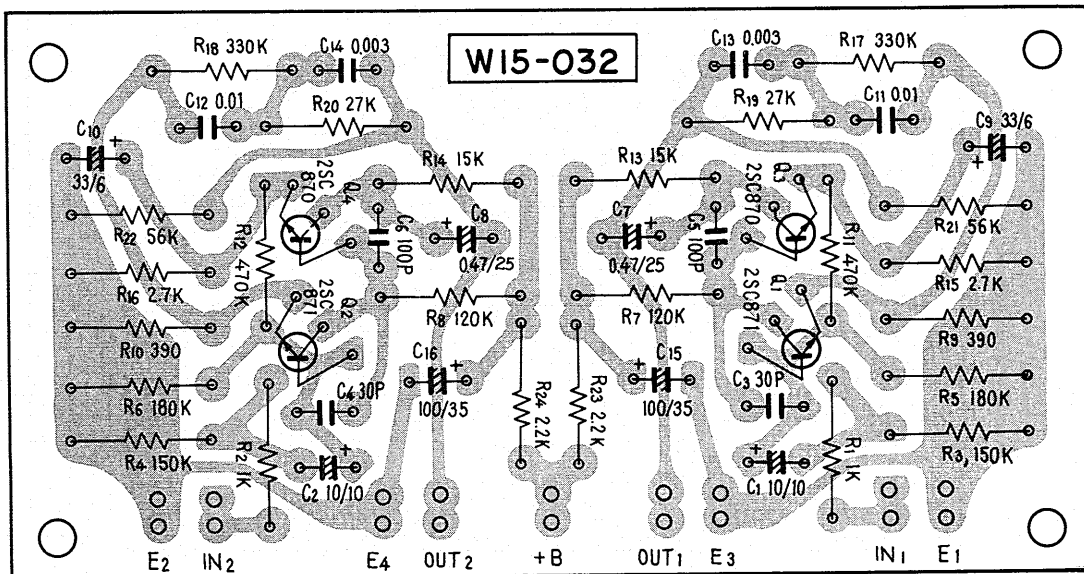
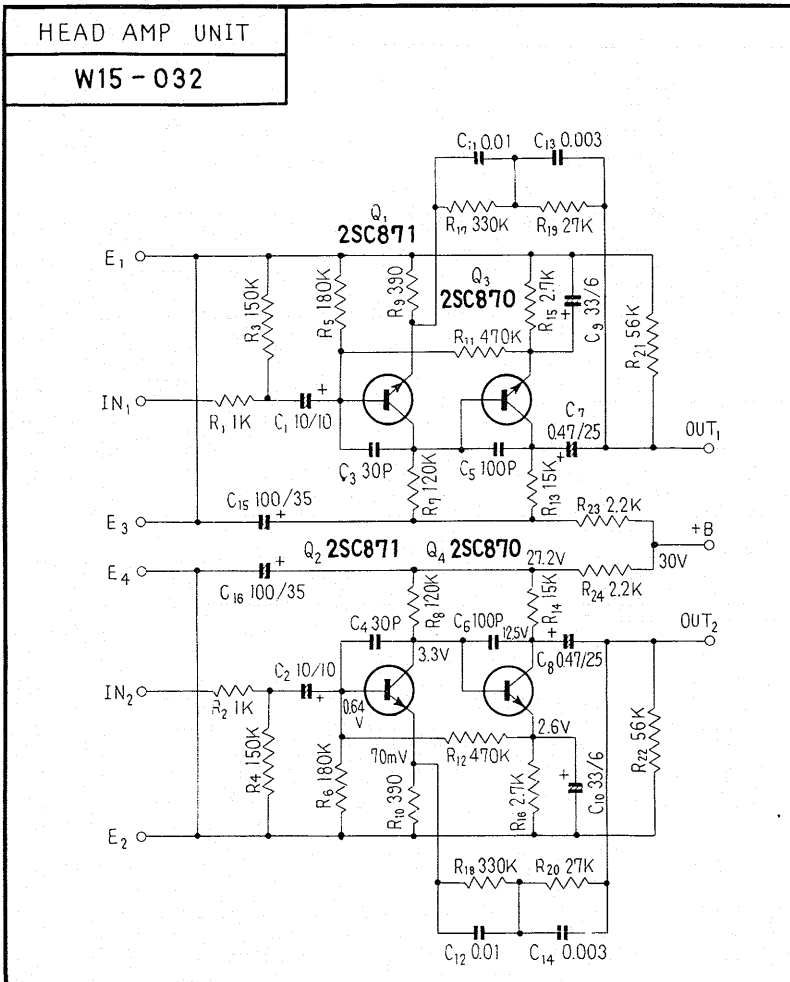

7-3 CONTROL AMP UNIT (AWG-001)

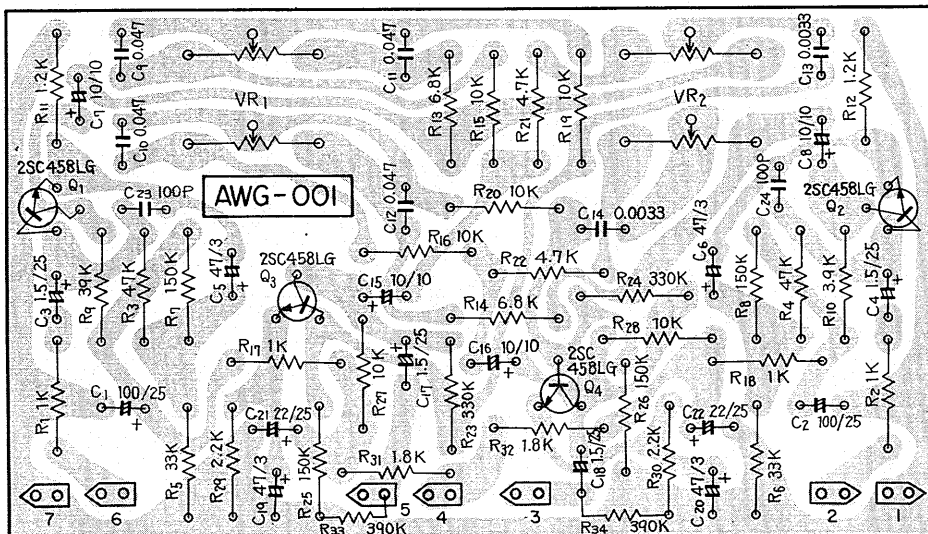
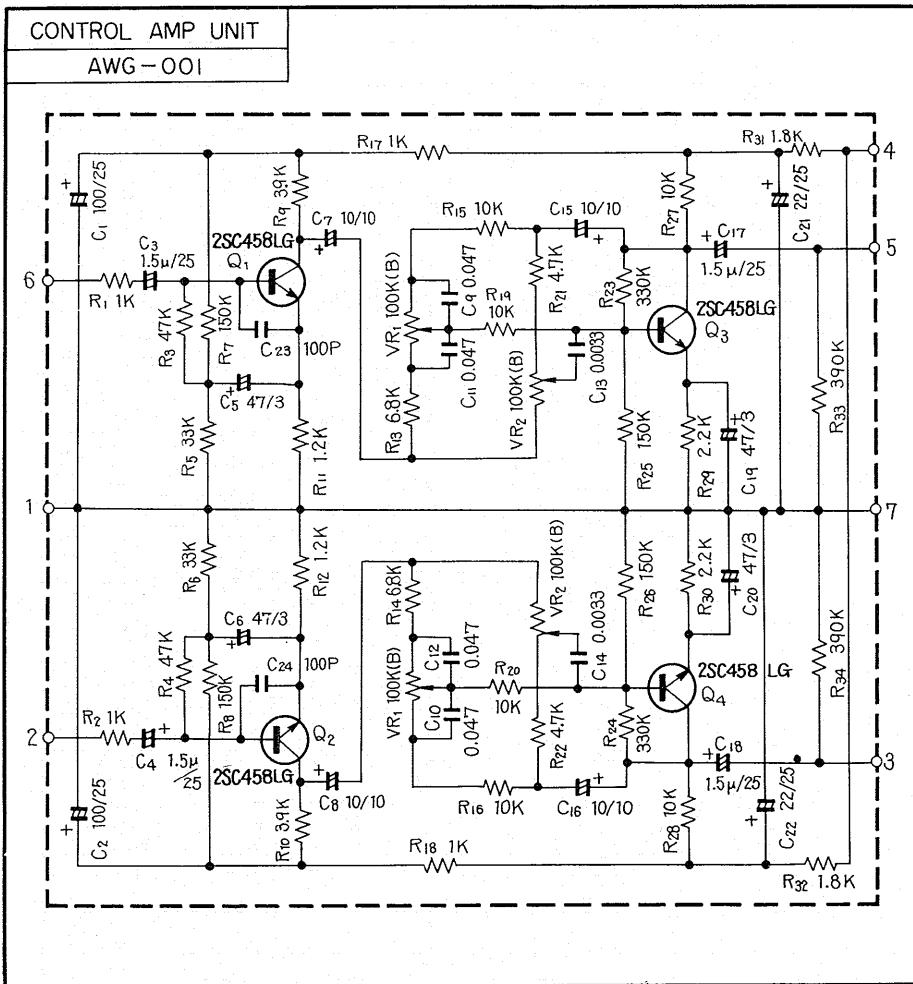

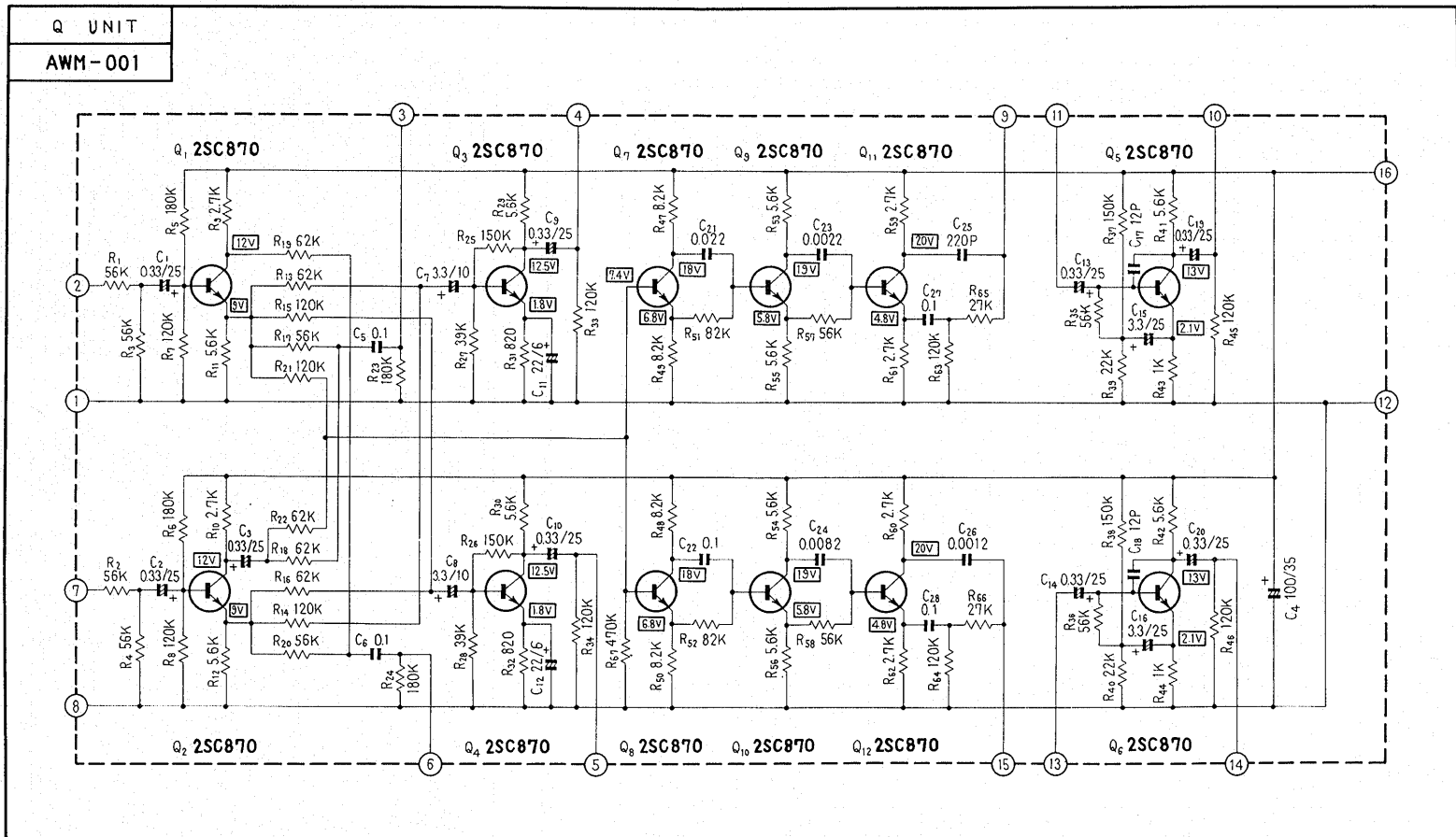

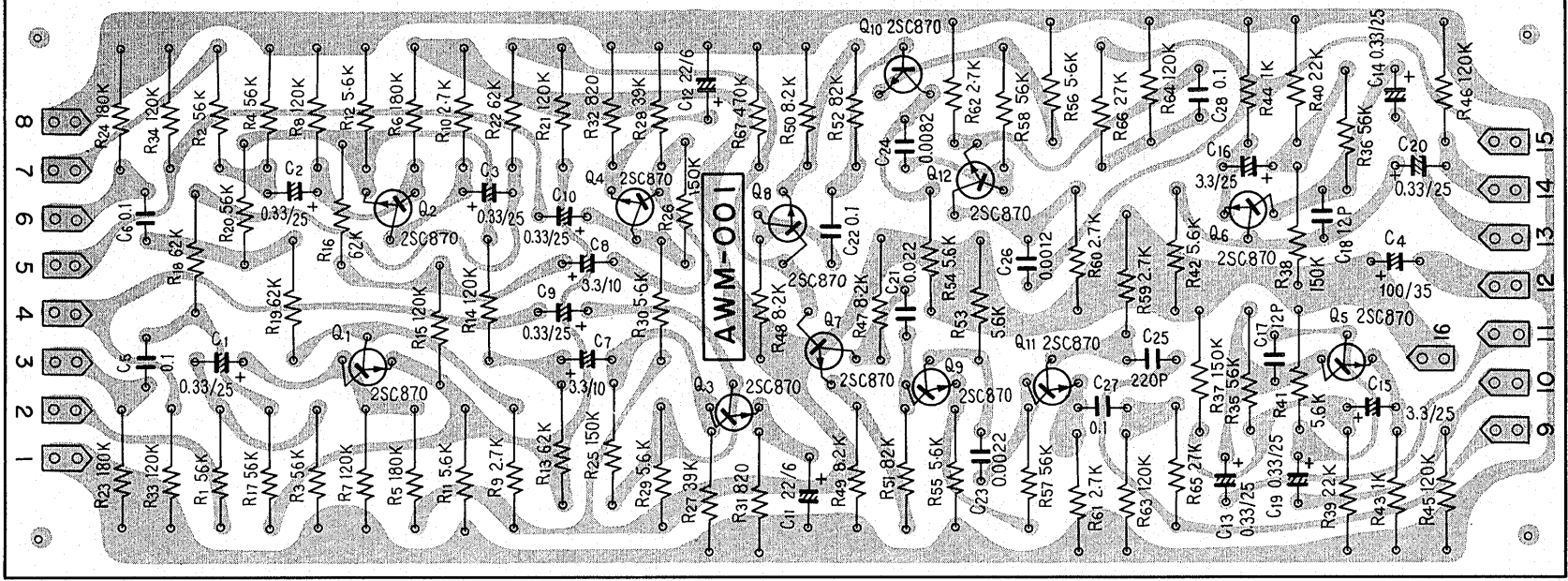

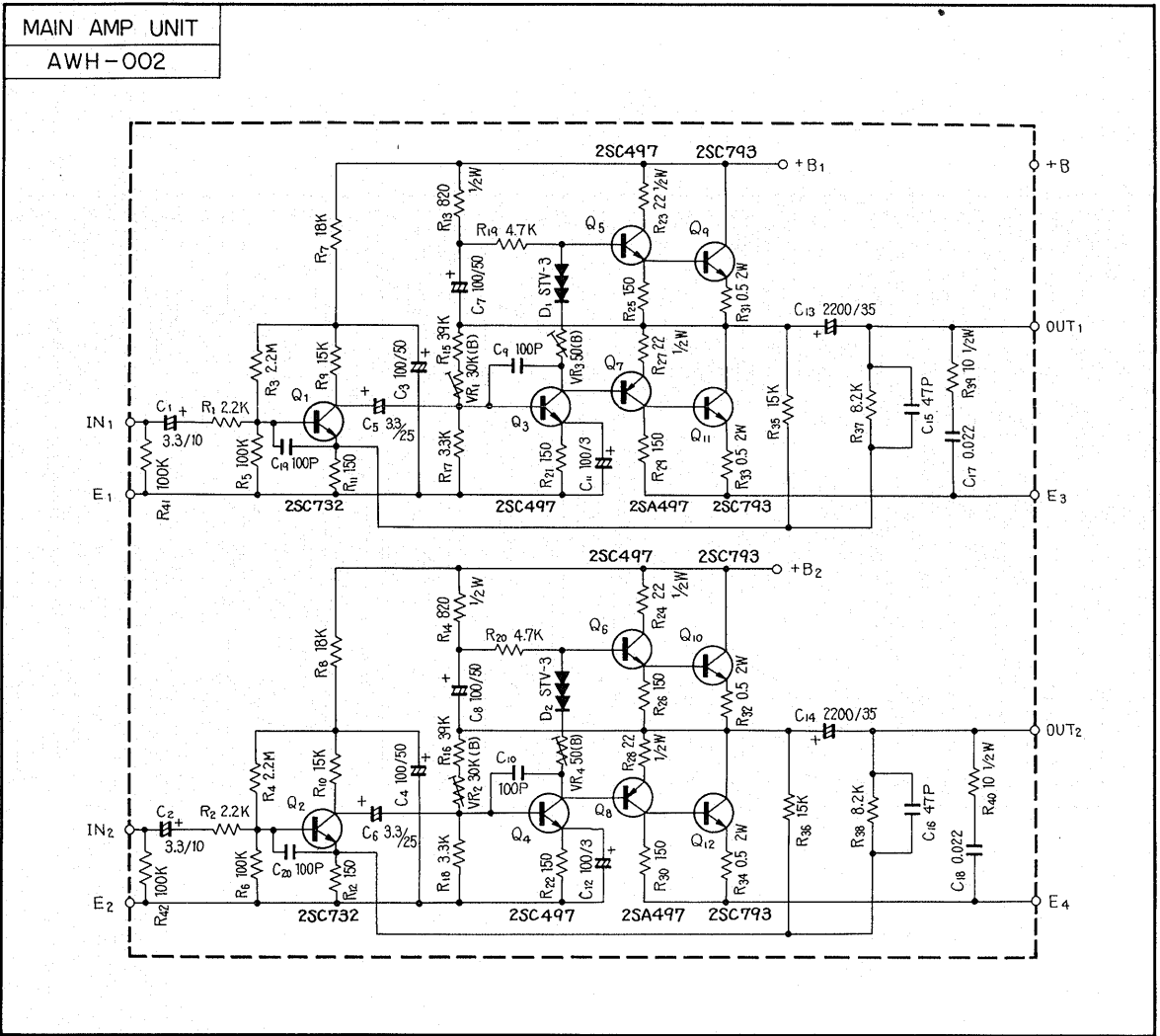

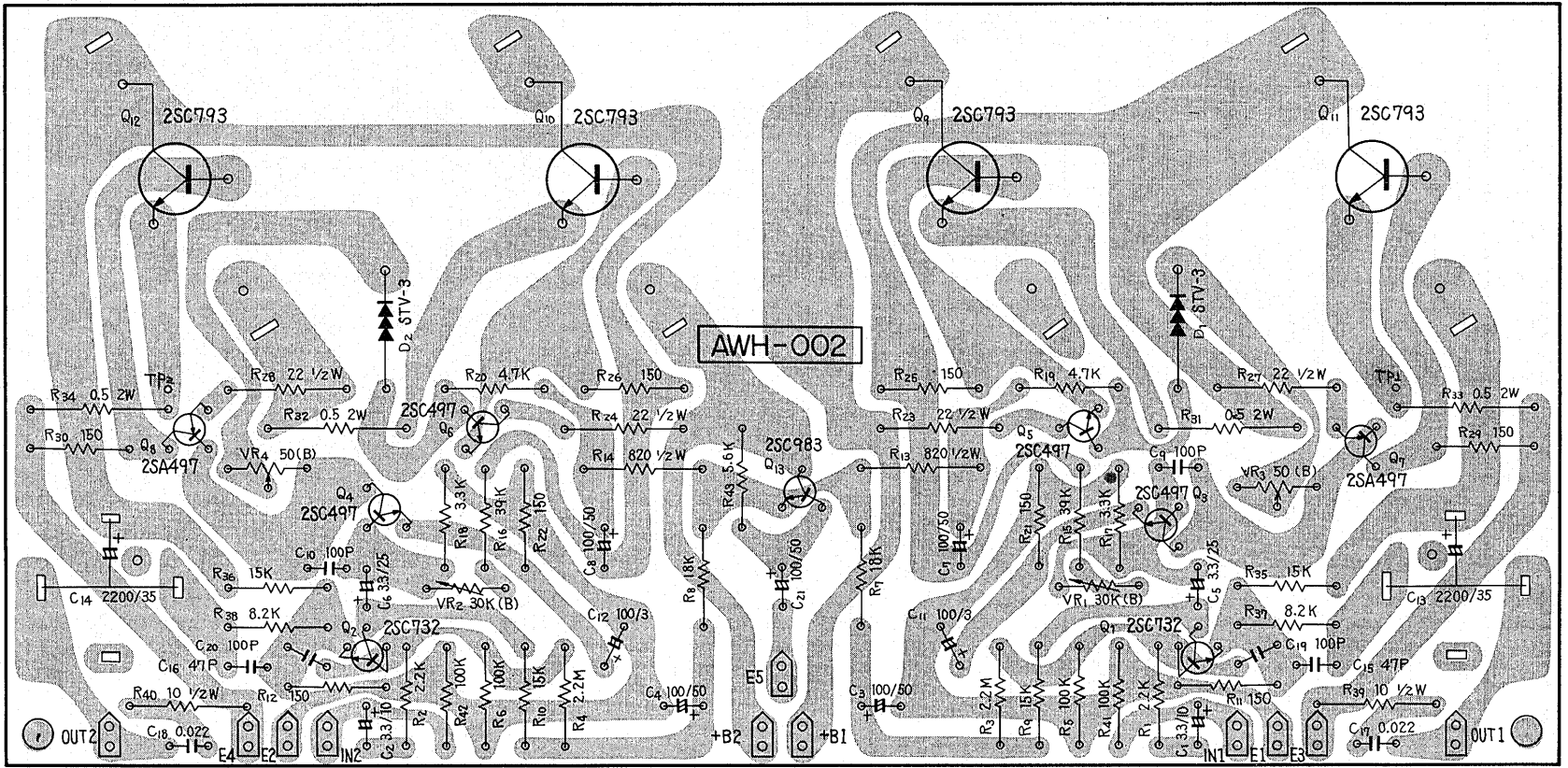

7-6 POWER SUPPLY UNIT (AWR-002)

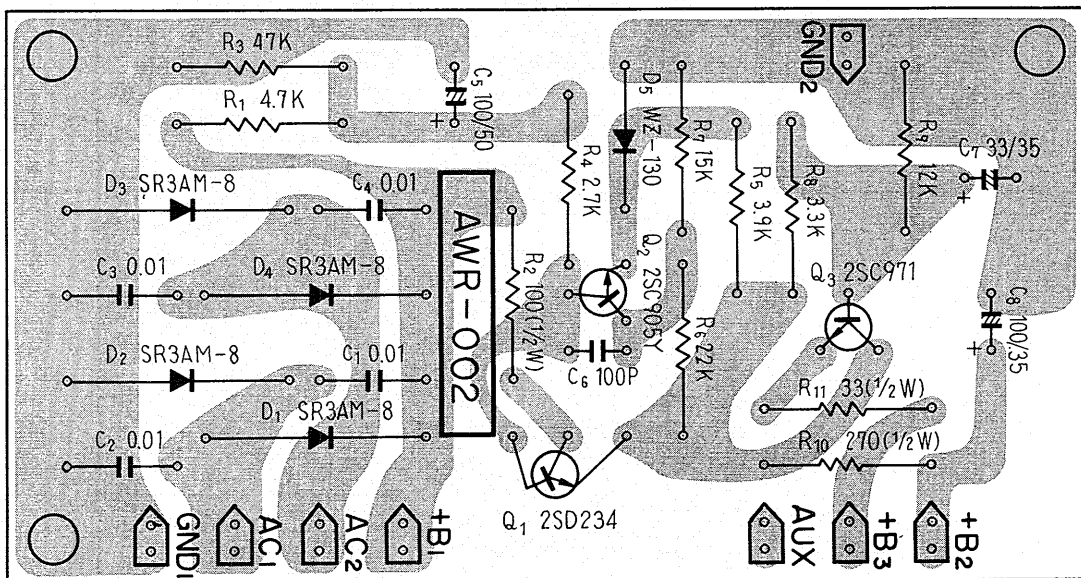
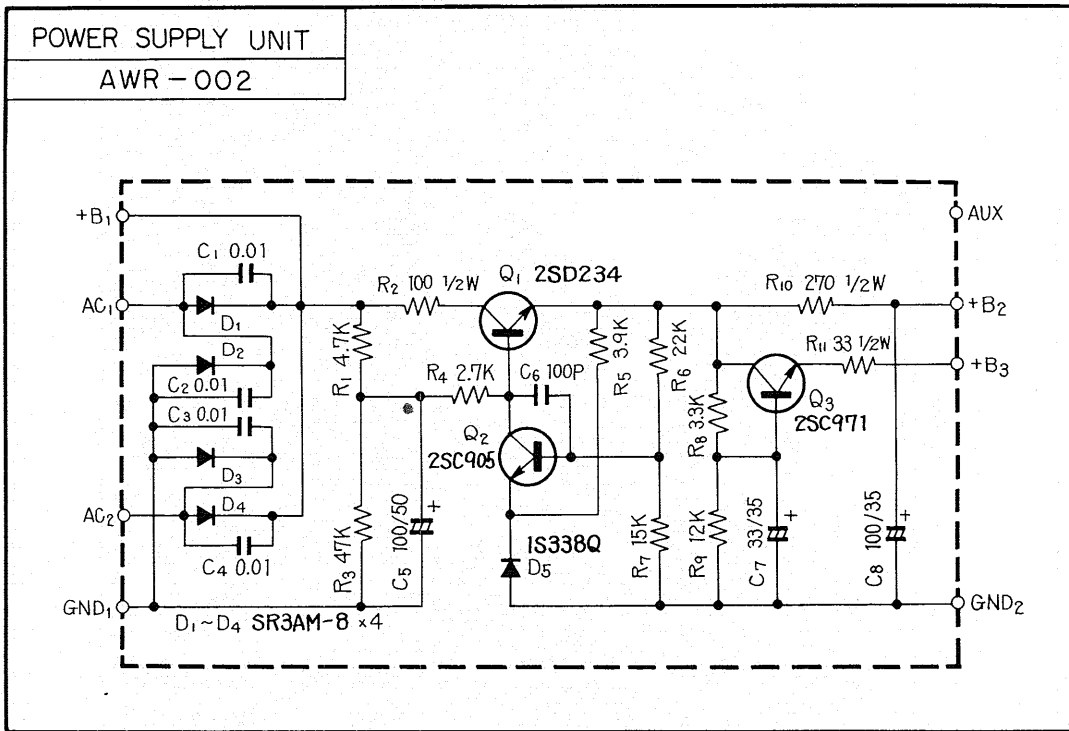

7-7 LEVER SWITCH UNIT (AWS-002)

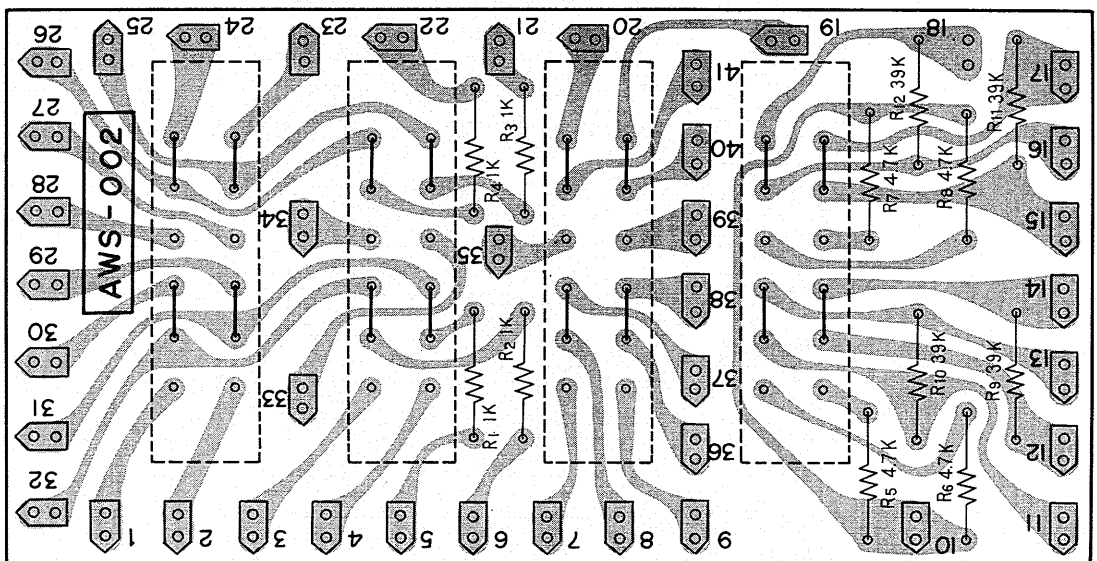
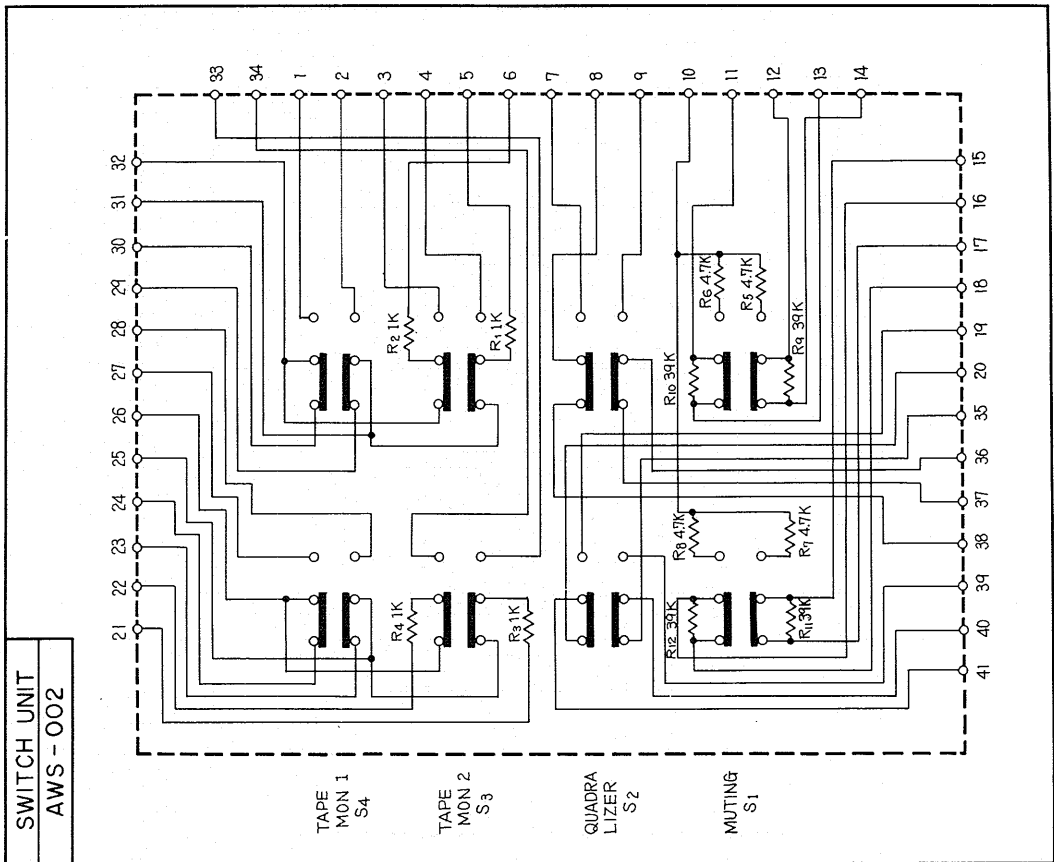

7-8 LEVER SWITCH UNIT (AWS-003)

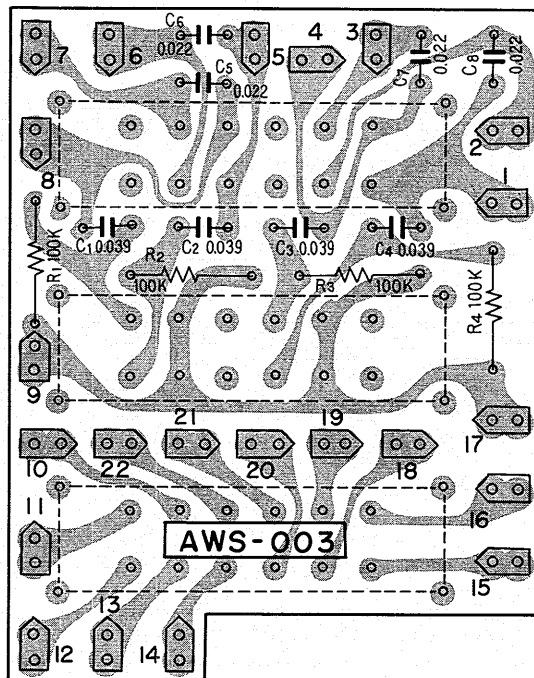
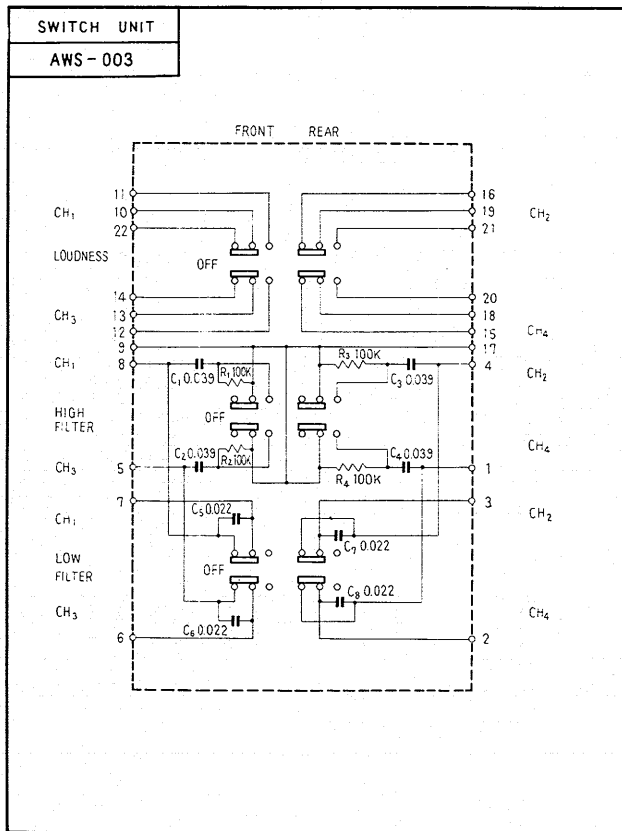

7-9 VOLUME UNIT (AWX-001)

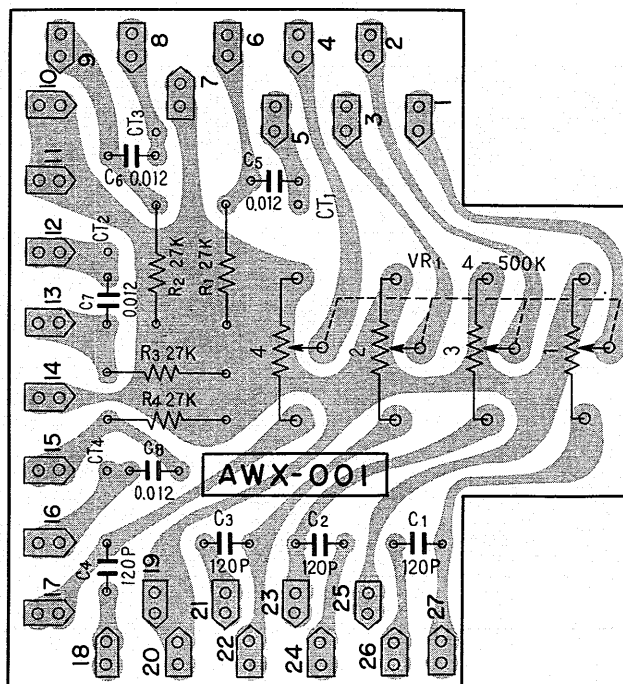
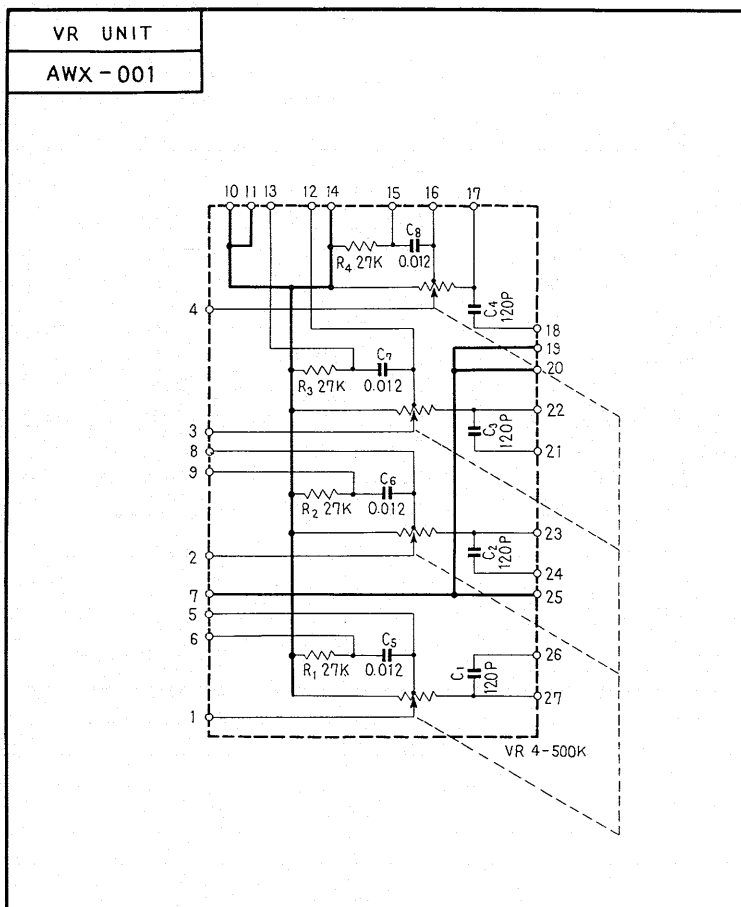

7-10 R UNIT (AWX-005)

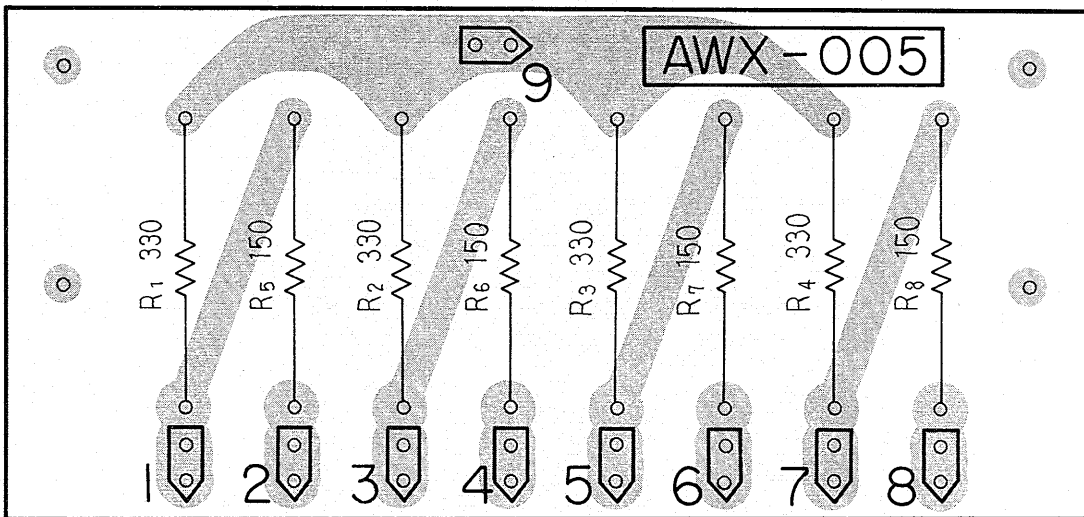
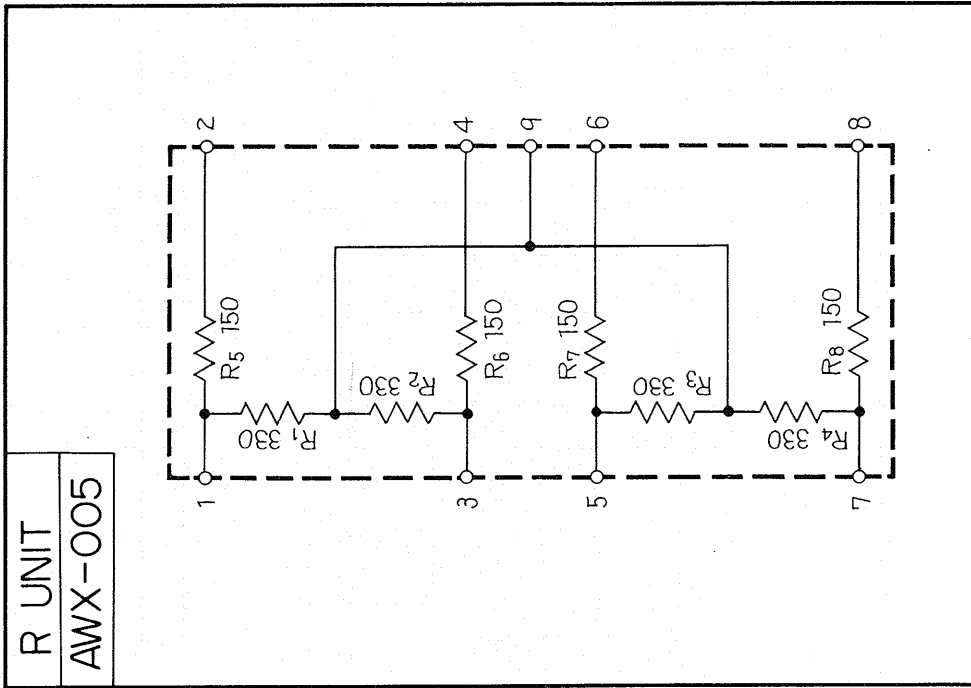

8. PARTS LIST

8-1 MISCELLANEOUS PARTS

CAPACITORS

IN μF UNLESS OTHERWISE NOTED. p: μF .

Symbol	Description	Part No.
C1	Ceramic 0.01 50V	CKDYF 103Z 50
C2	Ceramic 0.01 50V	CKDYF 103Z 50
C3	Ceramic 0.01 DC 1.4kV	C43-003-0
C4	Ceramic 0.01 DC 1.4kV	C43-003-0
C5	Ceramic 0.01 DC 1.4kV	C43-003-0
C6	Ceramic 0.01 DC 1.4kV	C43-003-0
C7	Ceramic 0.01 DC 1.4kV	C43-003-0
C8	Ceramic 0.01 DC 1.4kV	C43-003-0
C9	Electrolytic 4700 63V	ACH-003-A
C10	Ceramic 0.01 DC 1.4kV	C43-003-0

RESISTORS

IN Ω , $\frac{1}{2}\text{W}$ UNLESS OTHERWISE NOTED. k: $\text{k}\Omega$, M: $\text{M}\Omega$.

Symbol	Description	Part No.
R1	Carbon film 100k	RD $\frac{1}{4}$ PS 104K
R2	Carbon film 100k	RD $\frac{1}{4}$ PS 104K
R3	Carbon film 100k	RD $\frac{1}{4}$ PS 104K
R4	Carbon film 100k	RD $\frac{1}{4}$ PS 104K
R5	Carbon film 1k	RD $\frac{1}{4}$ PW 102KNL
R6	Carbon film 1k	RD $\frac{1}{4}$ PW 102KNL
R7	Carbon film 1k	RD $\frac{1}{4}$ PW 102KNL
R8	Carbon film 1k	RD $\frac{1}{4}$ PW 102KNL

SWITCHES

Symbol	Description	Part No.
S1	SELECTOR switch	ASC-007-0
S2	MODE switch	ASC-005-0
S3	SPEAKERS switch	ASA-005-0
S10	PRE & MAIN switch	ASH-001-0

OTHERS

Symbol	Description	Part No.
	Head amp unit	W15-032-0
	Control amp unit	AWG-001-0
	Main amp unit	AWH-002-B
	Q unit	AWM-001-A
	Power supply unit	AWR-002-0
	Lever switch unit	AWS-002-0
	Lever switch unit	AWS-003-0
	Volume unit	AWX-001-0
	R unit	AWX-005-0
	Wooden case	M52-139-C
	Front panel ass'y	ANB-066-0
	Foot	AEC-012-0
	Knob for volume, selector and mode	A12-229-A
	Knob for bass, treble and speakers	A12-232-A
	Knob for level control	A12-241-A
	Knob for lever switch	A19-095-A
	Quadraphonic badge	AAM-003-A
	4P input terminal board	K21-010-E
	18P input terminal board	AKB-001-0
	4P ground terminal	K13-047-0

8-2 HEAD AMP UNIT (W15-032)

Symbol	Description	Part No.	
	Pilot lamp	E22-020-0	
	Fuse 2A for protection	E21-035-A	
	Fuse 1A for protection	E21-020-0	
	Fuse 1.5A	E21-012-0	
	Spare AC outlet	K82-014-0	
	Speaker socket	K72-031-0	
	Fuse holder	K96-006-0	
	Fuse holder	AKR-001-0	
	Headphones jack	K72-026-0	
	Pilot lamp socket	K42-003-A	
	AC power cord	D11-002-B	
	Short pin plug	K71-028-0	
	Packing case	AHD-017-0	
	Protector for packing	H11-070-B	
	Screw to fix wooden case	B11-041-A	
	Screw for grounding	B11-012-A	
	Operating instructions	ARB-014-0	
	Connection cord (white)	D51-003-B	
	Connection cord (red)	D51-004-B	
	Pin plug	K72-015-A	
	Fuse 3A	E21-006-0	
	Speaker plug	K72-007-B	
	Power transformer	ATT-013-A	

POTENTIOMETERS

Symbol	Description	Part No.	
VR1	Level control, 500k-B	ACV-004-0	
VR2	Level control, 500k-B	ACV-004-0	
VR3	Level control, 500k-B	ACV-004-0	
VR4	Level control, 500k-B	ACV-004-0	

CAPACITORS

Symbol	Description	Part No.	
C1	Electrolytic 10 10V	CEA 100P 10	
C2	Electrolytic 10 10V	CEA 100P 10	
C3	Ceramic 30p 50V	CCDSL 300K 50	
C4	Ceramic 30p 50V	CCDSL 300K 50	
C5	Ceramic 100p 50V	CCDSL 101K 50	
C6	Ceramic 100p 50V	CCDSL 101K 50	
C7	Electrolytic 0.47 25V	CSSA R47M 25	
C8	Electrolytic 0.47 25V	CSSA R47M 25	
C9	Electrolytic 33 6V	CEA 330P 6	
C10	Electrolytic 33 6V	CEA 330P 6	
C11	Mylar 0.01 50V	CQMA 103M 50	
C12	Mylar 0.01 50V	CQMA 103M 50	
C13	Mylar 0.003 50V	CQMA 302M 50	
C14	Mylar 0.003 50V	CQMA 302M 50	
C15	Electrolytic 100 35V	CEA 101P 35	
C16	Electrolytic 100 35V	CEA 101P 35	
C17	Ceramic 100p 50V	CCDSL 101K 50	
C18	Ceramic 100p 50V	CCDSL 101K 50	

RESISTORS

Symbol	Description	Part No.	
R1	Carbon film 1k	RD $\frac{1}{4}$ PS 102K	
R2	Carbon film 1k	RD $\frac{1}{4}$ PS 102K	
R3	Carbon film 150k	RD $\frac{1}{4}$ PS 154K	
R4	Carbon film 150k	RD $\frac{1}{4}$ PS 154K	
R5	Carbon film 180k	RD $\frac{1}{4}$ PS 184K	

8-3 CONTROL AMP UNIT (AWG-001)

CAPACITORS

Symbol	Description	Part No.
R6	Carbon film 180k	RD¼PS 184K
R7	Carbon film 120k	RD¼PS 124K
R8	Carbon film 120k	RD¼PS 124K
R9	Carbon film 390	RD¼PS 391K
R10	Carbon film 390	RD¼PS 391K
R11	Carbon film 470k	RD¼PS 474K
R12	Carbon film 470k	RD¼PS 474K
R13	Carbon film 15k	RD¼PS 153K
R14	Carbon film 15k	RD¼PS 153K
R15	Carbon film 2.7k	RD¼PS 272K
R16	Carbon film 2.7k	RD¼PS 272K
R17	Carbon film 330k	RD¼PS 334K
R18	Carbon film 330k	RD¼PS 334K
R19	Carbon film 27k	RD¼PS 273K
R20	Carbon film 27k	RD¼PS 273K
R21	Carbon film 56k	RD¼PS 563K
R22	Carbon film 56k	RD¼PS 563K
R23	Carbon film 2.2k	RD¼PS 222K
R24	Carbon film 2.2k	RD¼PS 222K

TRANSISTORS

Symbol	Description	Part No.
Q1	2SC871 GR or BL	
Q2	2SC871 GR or BL	
Q3	2SC870	
Q4	2SC870	

Symbol	Description	Part No.
C1	Electrolytic 100 25V	CEA 101P 25
C2	Electrolytic 100 25V	CEA 101P 25
C3	Electrolytic 1.5 25V	CSSA 1R5X 25
C4	Electrolytic 1.5 25V	CSSA 1R5X 25
C5	Electrolytic 47 3V	CEA 470P 3
C6	Electrolytic 47 3V	CEA 470P 3
C7	Electrolytic 10 16V	CEA 100P 16
C8	Electrolytic 10 16V	CEA 100P 16
C9	Mylar 0.047 50V	CQMA 473M 50
C10	Mylar 0.047 50V	CQMA 473M 50
C11	Mylar 0.047 50V	CQMA 473M 50
C12	Mylar 0.047 50V	CQMA 473M 50
C13	Mylar 0.0033 50V	CQMA 332M 50
C14	Mylar 0.0033 50V	CQMA 332M 50
C15	Electrolytic 10 16V	CEA 100P 16
C16	Electrolytic 10 16V	CEA 100P 16
C17	Electrolytic 1.5 25V	CSSA 1R5X 25
C18	Electrolytic 1.5 25V	CSSA 1R5X 25
C19	Electrolytic 47 3V	CEA 470P 3
C20	Electrolytic 47 3V	CEA 470P 3
C21	Electrolytic 22 25V	CEA 220P 25
C22	Electrolytic 22 25V	CEA 220P 25
C23	Ceramic 100p 50V	CCDSL 101K 50
C24	Ceramic 100p 50V	CCDSL 101K 50

RESISTORS

Symbol	Description	Part No.
R1	Carbon film 1k	RD%PS 102K
R2	Carbon film 1k	RD%PS 102K
R3	Carbon film 47k	RD%PS 473K
R4	Carbon film 47k	RD%PS 473K
R5	Carbon film 33k	RD%PS 333K
R6	Carbon film 33k	RD%PS 333K
R7	Carbon film 150k	RD%PS 154K
R8	Carbon film 150k	RD%PS 154K
R9	Carbon film 3.9k	RD%PS 392K
R10	Carbon film 3.9k	RD%PS 392K
R11	Carbon film 1.2k	RD%PS 122K
R12	Carbon film 1.2k	RD%PS 122K
R13	Carbon film 6.8k	RD%PS 682K
R14	Carbon film 6.8k	RD%PS 682K
R15	Carbon film 10k	RD%PS 103K
R16	Carbon film 10k	RD%PS 103K
R17	Carbon film 1k	RD%PS 102K
R18	Carbon film 1k	RD%PS 102K
R19	Carbon film 10k	RD%PS 103K
R20	Carbon film 10k	RD%PS 103K
R21	Carbon film 4.7k	RD%PS 472K
R22	Carbon film 4.7k	RD%PS 472K
R23	Carbon film 330k	RD%PS 334K
R24	Carbon film 330k	RD%PS 334K
R25	Carbon film 150k	RD%PS 154K
R26	Carbon film 150k	RD%PS 154K
R27	Carbon film 10k	RD%PS 103K
R28	Carbon film 10k	RD%PS 103K
R29	Carbon film 2.2k	RD%PS 222K
R30	Carbon film 2.2k	RD%PS 222K

Symbol	Description	Part No.
R31	Carbon film 1.8k	RD%PS 182K
R32	Carbon film 1.8k	RD%PS 182K
R33	Carbon film 390k	RD%PS 394K
R34	Carbon film 390k	RD%PS 394K
VR1	Bass control, 100k - B	C82-050-0
VR2	Treble control, 100k - B	C82-050-0

TRANSISTORS

Symbol	Description	Part No.
Q1	2SC458LG-B or C	
Q2	2SC458LG-B or C	
Q3	2SC458LG-B or C	
Q4	2SC458LG-B or C	

8-4 MAIN AMP UNIT (AWH-002)

CAPACITORS

Symbol	Description	Part No.
C1	Electrolytic 3.3 10V	CEA 3R3P 10
C2	Electrolytic 3.3 10V	CEA 3R3P 10
C3	Electrolytic 100 50V	CEA 101P 50
C4	Electrolytic 100 50V	CEA 101P 50
C5	Electrolytic 3.3 25V	CEA 3R3P 25
C6	Electrolytic 3.3 25V	CEA 3R3P 25
C7	Electrolytic 100 50V	CEA 101P 50
C8	Electrolytic 100 50V	CEA 101P 50
C9	Ceramic 100p 50V	CCDSL 101K 50
C10	Ceramic 100p 50V	CCDSL 101K 50

Symbol	Description			Part No.
C11	Electrolytic	100	6V	CEA 101P 6
C12	Electrolytic	100	6V	CEA 101P 6
C13	Electrolytic	2200	35V	ACH-004-0
C14	Electrolytic	2200	35V	ACH-004-0
C15	Ceramic	47p	50V	CCDSL 470K 50
C16	Ceramic	47p	50V	CCDSL 470K 50
C17	Mylar	0.022	50V	QOMA 223M 50
C18	Mylar	0.022	50V	QOMA 223M 50
C19	Ceramic	100p	50V	CCDSL 101K 50
C20	Ceramic	100p	50V	CCDSL 101K 50

RESISTORS

Symbol	Description			Part No.
R1	Carbon film	2.2k		RD½PS 222K
R2	Carbon film	2.2k		RD½PS 222K
R3	Carbon film	2.2M		RD½PS 225K
R4	Carbon film	2.2M		RD½PS 225K
R5	Carbon film	100k		RD½PS 104K
R6	Carbon film	100k		RD½PS 104K
R7	Carbon film	18k		RD½PS 183K
R8	Carbon film	18k		RD½PS 183K
R9	Carbon film	15k		RD½PS 153K
R10	Carbon film	15k		RD½PS 153K
R11	Carbon film	150		RD½PS 151K
R12	Carbon film	150		RD½PS 151K
R13	Carbon film	820	½W	RD½PS 821K
R14	Carbon film	820	½W	RD½PS 821K
R15	Carbon film	39k		RD½PS 393K
R16	Carbon film	39k		RD½PS 393K
R17	Carbon film	3.3k		RD½PS 332K
R18	Carbon film	3.3k		RD½PS 332K
R19	Carbon film	4.7k		RD½PS 472K
R20	Carbon film	4.7k		RD½PS 472K

Symbol	Description			Part No.
R21	Carbon film	150		RD½PS 151K
R22	Carbon film	150		RD½PS 151K
R23	Carbon film	22	½W	RD½PS 220K
R24	Carbon film	22	½W	RD½PS 220K
R25	Carbon film	150		RD½PS 151K
R26	Carbon film	150		RD½PS 151K
R27	Carbon film	22	½W	RD½PS 220K
R28	Carbon film	22	½W	RD½PS 220K
R29	Carbon film	150		RD½PS 151K
R30	Carbon film	150		RD½PS 151K
R31	Wire wound	0.5	2W	RT2P 0R5K
R32	Wire wound	0.5	2W	RT2P 0R5K
R33	Wire wound	0.5	2W	RT2P 0R5K
R34	Wire wound	0.5	2W	RT2P 0R5K
R35	Carbon film	15k		RD½PS 153K
R36	Carbon film	15k		RD½PS 153K
R37	Carbon film	8.2k		RD½PS 822K
R38	Carbon film	8.2k		RD½PS 822K
R39	Carbon film	10	½W	RD½PS 100K
R40	Carbon film	10	½W	RD½PS 100K
R41	Carbon film	100k		RD½PS 104K
R42	Carbon film	100k		RD½PS 104K
VR1	Semi-fixed	30k-B		C92-024-B
VR2	Semi-fixed	30k-B		C92-024-B
VR3	Semi-fixed	50-B		C92-043-A
VR4	Semi-fixed	50-B		C92-043-A

SEMICONDUCTORS

Symbol	Description	Part No.	
Q1	2SC732 Transistor		
Q2	2SC732 Transistor		
Q3	2SC497-O or Y Transistor		
Q4	2SC497-O or Y Transistor		
Q5	2SC497-O or Y Transistor		
Q6	2SC497-O or Y Transistor		
Q7	2SA497-O or Y Transistor		
Q8	2SA497-O or Y Transistor		
Q9	2SC793-Y Transistor		
Q10	2SC793-Y Transistor		
Q11	2SC793-Y Transistor		
Q12	2SC793-Y Transistor		
D1	STV-3 Varistor		
D2	STV-3 Varistor		

8-5 POWER SUPPLY UNIT (AWR-002)

CAPACITORS

Symbol	Description	Part No.	
C1	Ceramic 0.01 DC 1.4kV	C43-003-0	
C2	Ceramic 0.01 DC 1.4kV	C43-003-0	
C3	Ceramic 0.01 DC 1.4kV	C43-003-0	
C4	Ceramic 0.01 DC 1.4kV	C43-003-0	
C5	Electrolytic 100 50V	CEA 101P 50	
C6	Ceramic 100p 50V	CCDSL 101K 50	
C7	Electrolytic 33 35V	CEA 330P 35	
C8	Electrolytic 100 35V	CEA 101P 35	

RESISTORS

Symbol	Description	Part No.	
R1	Carbon film 4.7k	RD½PS 472K	
R2	Carbon film 100 ½W	RD½PS 101K	
R3	Carbon film 47k	RD½PS 473K	
R4	Carbon film 2.7k	RD½PS 272K	
R5	Carbon film 3.9k	RD½PS 392K	
R6	Carbon film 22k	RD½PS 223K	
R7	Carbon film 15k	RD½PS 153K	
R8	Carbon film 3.3k	RD½PS 332K	
R9	Carbon film 12k	RD½PS 123K	
R10	Carbon film 270 ½W	RD½PS 271K	
R11	Carbon film 33 ½W	RD½PS 330K	

SEMICONDUCTORS

Symbol	Description	Part No.	
Q1	2SD234P-O or Y Transistor		
Q2	2SC905-Y or G Transistor		
Q3	2SC971-3 or 2 Transistor		
D1	SR3AM-8 Diode		
D2	SR3AM-8 Diode		
D3	SR3AM-8 Diode		
D4	SR3AM-8 Diode		
D5	1S338Q Zener diode		

8-6 LEVER SWITCH UNIT (AWS-003)

CAPACITORS

Symbol	Description			Part No.
C1	Mylar	0.039	50V	CQMA 393K 50
C2	Mylar	0.039	50V	CQMA 393K 50
C3	Mylar	0.039	50V	CQMA 393K 50
C4	Mylar	0.039	50V	CQMA 393K 50
C5	Mylar	0.022	50V	CQMA 223K 50
C6	Mylar	0.022	50V	CQMA 223K 50
C7	Mylar	0.022	50V	CQMA 223K 50
C8	Mylar	0.022	50V	CQMA 223K 50

RESISTORS

Symbol	Description			Part No.
R1	Carbon film	100k		RD¼PS 104KNL
R2	Carbon film	100k		RD¼PS 104KNL
R3	Carbon film	100k		RD¼PS 104KNL
R4	Carbon film	100k		RD¼PS 104KNL

SWITCHES

Symbol	Description	Part No.
S1	Lever switch	ASK-004-O
S2	Lever switch	ASK-004-O
S3	Lever switch	ASK-004-O

8-7 VOLUME UNIT (AWX-001)

CAPACITORS

Symbol	Description			Part No.
C1	Ceramic	120p	50V	CCDSL 121K 50
C2	Ceramic	120p	50V	CCDSL 121K 50
C3	Ceramic	120p	50V	CCDSL 121K 50
C4	Ceramic	120p	50V	CCDSL 121K 50
C5	Mylar	0.012	50V	CQMA 123K 50
C6	Mylar	0.012	50V	CQMA 123K 50
C7	Mylar	0.012	50V	CQMA 123K 50
C8	Mylar	0.012	50V	CQMA 123K 50

RESISTORS

Symbol	Description			Part No.
R1	Carbon film	27k		RD¼PS 273K
R2	Carbon film	27k		RD¼PS 273K
R3	Carbon film	27k		RD¼PS 273K
R4	Carbon film	27k		RD¼PS 273K
VR1	4 gang, 500k-B	VOLUME		ACV-302-O

8-8 R UNIT (AWX-005)

RESISTORS

Symbol	Description			Part No.
R1	Metal oxide	330	2W	RS2P 331K
R2	Metal oxide	330	2W	RS2P 331K
R3	Metal oxide	330	2W	RS2P 331K
R4	Metal oxide	330	2W	RS2P 331K
R5	Metal oxide	150	2W	RS2P 151K
R6	Metal oxide	150	2W	RS2P 151K
R7	Metal oxide	150	2W	RS2P 151K
R8	Metal oxide	150	2W	RS2P 151K

NOTE: When Serial Numbers of this model become No. 14501, thereafter use the following CIRCUIT DIAGRAM, PCB, and PARTS LIST newly prepared for repair service of MAIN AMP UNIT.

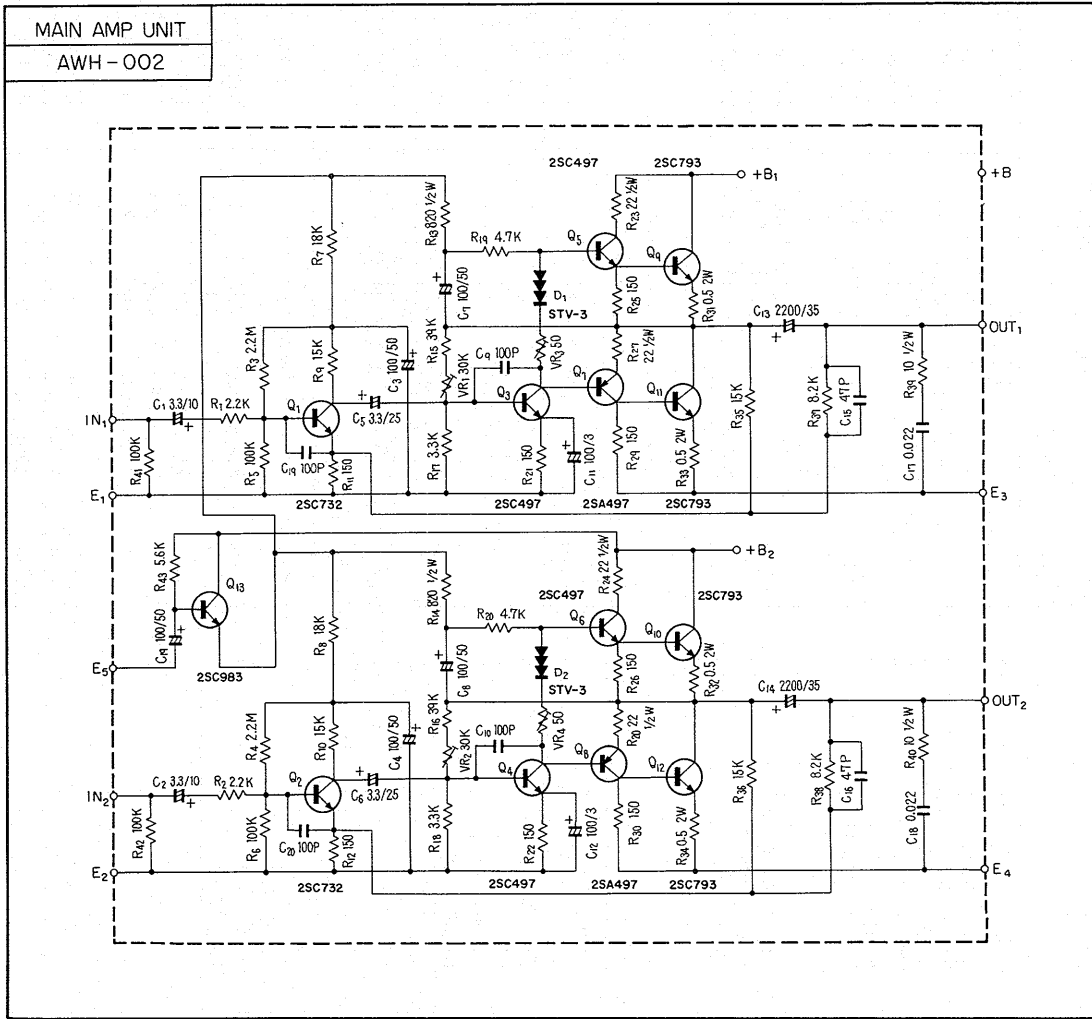

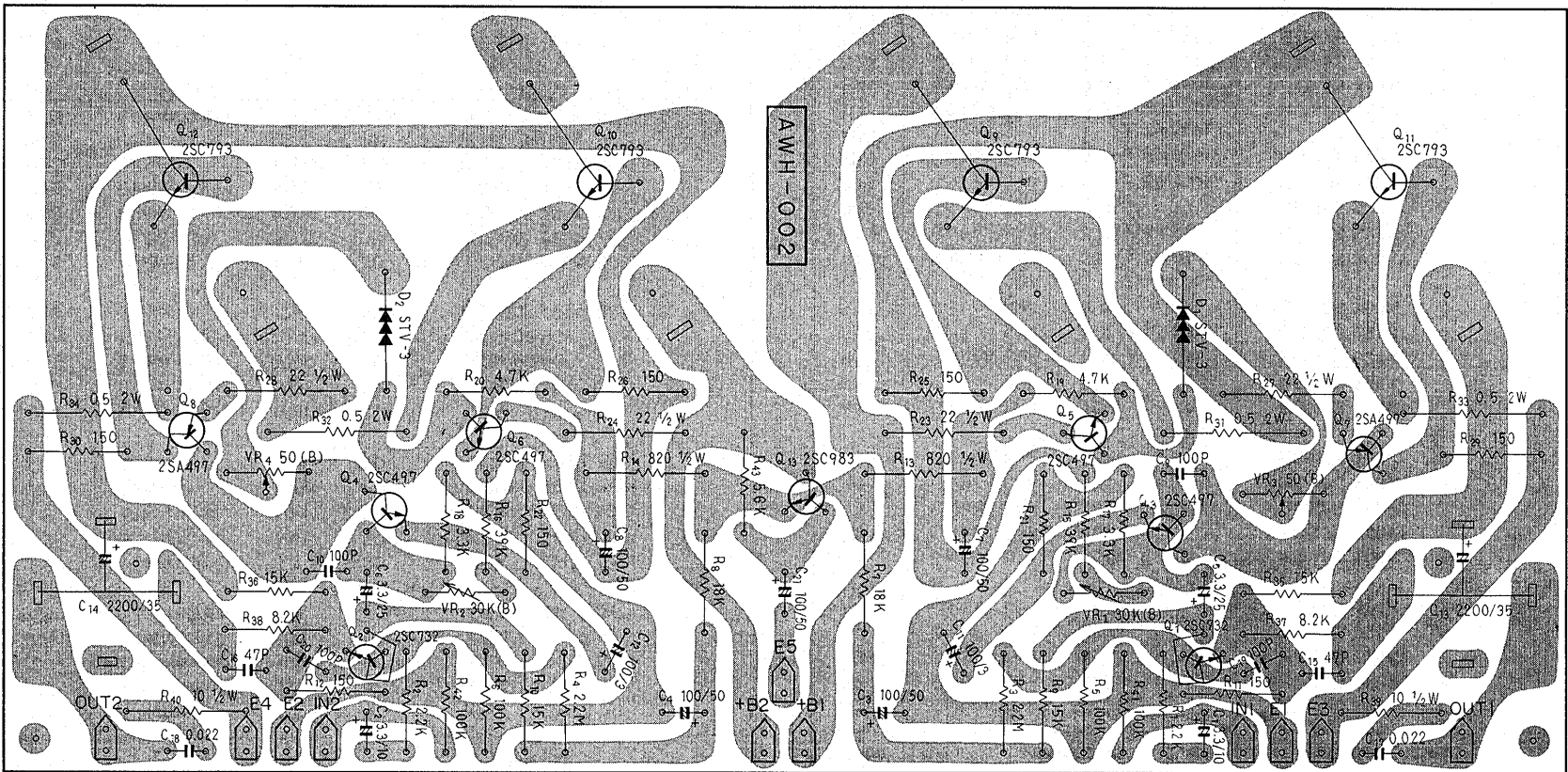

MAIN AMP UNIT (AWH-002)

CAPACITORS

Symbol	Description			Part No.
C1	Electrolytic	3.3	10V	CEA 3R3P 10
C2	Electrolytic	3.3	10V	CEA 3R3P 10
C3	Electrolytic	100	50V	CEA 101P 50
C4	Electrolytic	100	50V	CEA 101P 50
C5	Electrolytic	3.3	25V	CEA 3R3P 25
C6	Electrolytic	3.3	25V	CEA 3R3P 25
C7	Electrolytic	100	50V	CEA 101P 50
C8	Electrolytic	100	50V	CEA 101P 50
C9	Ceramic	100p	50V	CCDSL 101K 50
C10	Ceramic	100p	50V	CCDSL 101K 50
C11	Electrolytic	100	6V	CEA 101P 6
C12	Electrolytic	100	6V	CEA 101P 6
C13	Electrolytic	2200	35V	ACH-004-0
C14	Electrolytic	2200	35V	ACH-004-0
C15	Ceramic	47p	50V	CCDSL 470K 50
C16	Ceramic	47p	50V	CCDSL 470K 50
C17	Mylar	0.022	50V	CQMA 223M 50
C18	Mylar	0.022	50V	CQMA 223M 50
C19	Ceramic	100p	50V	CCDSL 101K 50
C20	Ceramic	100p	50V	CCDSL 101K 50
C21	Electrolytic	100	50V	CEA 101P 50

RESISTORS

Symbol	Description			Part No.
R1	Carbon film	2.2k		RD¼PS 222K
R2	Carbon film	2.2k		RD¼PS 222K
R3	Carbon film	2.2M		RD¼PS 225K
R4	Carbon film	2.2M		RD¼PS 225K
R5	Carbon film	100k		RD¼PS 104K
R6	Carbon film	100k		RD¼PS 104K
R7	Carbon film	18k		RD¼PS 183K
R8	Carbon film	18k		RD¼PS 183K
R9	Carbon film	15k		RD¼PS 153K
R10	Carbon film	15k		RD¼PS 153K
R11	Carbon film	150		RD¼PS 151K
R12	Carbon film	150		RD¼PS 151K
R13	Carbon film	820	½W	RD¼PS 821K
R14	Carbon film	820	½W	RD¼PS 821K
R15	Carbon film	39k		RD¼PS 393K
R16	Carbon film	39k		RD¼PS 393K
R17	Carbon film	3.3k		RD¼PS 332K
R18	Carbon film	3.3k		RD¼PS 332K
R19	Carbon film	4.7k		RD¼PS 472K
R20	Carbon film	4.7k		RD¼PS 472K
R21	Carbon film	150		RD¼PS 151K
R22	Carbon film	150		RD¼PS 151K
R23	Carbon film	22	½W	RD¼PS 220K
R24	Carbon film	22	½W	RD¼PS 220K
R25	Carbon film	150		RD¼PS 151K
R26	Carbon film	150		RD¼PS 151K
R27	Carbon film	22	½W	RD¼PS 220K
R28	Carbon film	22	½W	RD¼PS 220K
R29	Carbon film	150		RD¼PS 151K
R30	Carbon film	150		RD¼PS 151K

Symbol	Description			Part No.
R31	Wire wound	0.5	2W	RT2P 0R5K
R32	Wire wound	0.5	2W	RT2P 0R5K
R33	Wire wound	0.5	2W	RT2P 0R5K
R34	Wire wound	0.5	2W	RT2P 0R5K
R35	Carbon film	15k		RD¼PS 153K
R36	Carbon film	15k		RD¼PS 153K
R37	Carbon film	8.2k		RD¼PS 822K
R38	Carbon film	8.2k		RD¼PS 822K
R39	Carbon film	10	½W	RD½PS 100K
R40	Carbon film	10	½W	RD½PS 100K
R41	Carbon film	100k		RD¼PS 104K
R42	Carbon film	100k		RD¼PS 104K
R43	Carbon film	5.6k		RD¼PS 562J
VR1	Semi-fixed	30k-B		C92-024-B
VR2	Semi-fixed	30k-B		C92-024-B
VR3	Semi-fixed	50-B		C92-043-A
VR4	Semi-fixed	50-B		C92-043-A

SEMICONDUCTORS

Symbol	Description		Part No.
Q1	2SC732	Transistor	
Q2	2SC732	Transistor	
Q3	2SC497-O or Y	Transistor	
Q4	2SC497-O or Y	Transistor	
Q5	2SC497-O or Y	Transistor	
Q6	2SC497-O or Y	Transistor	
Q7	2SA497-O or Y	Transistor	
Q8	2SA497-O or Y	Transistor	
Q9	2SC793-Y	Transistor	
Q10	2SC793-Y	Transistor	
Q11	2SC793-Y	Transistor	
Q12	2SC793-Y	Transistor	
Q13	2SC983-O or Y	Transistor	
D1	STV-3	Varistor	
D2	STV-3	Varistor	

MEMO

PIONEER ELECTRONIC CORPORATION

15-5, 4-Chome, Ohmori-nishi, Ohta-ku, Tokyo, Japan

U.S. PIONEER ELECTRONICS CORPORATION

178 Commerce Road, Carlstadt New Jersey 07072 U.S.A.

PIONEER ELECTRONIC (EUROPE) N.V.

Noorderlaan 83, 2030 Antwerp, Belgium

COPYRIGHT SEPT. 1971 PRINTED IN JAPAN